



Installation Instructions

Fuel level sender kit p/n 220.003, 220.004 and 220.005

Fuel sender installation inside the tank

To install the tank unit sender into the fuel tank using a flange kit:

1. Cut a 59 mm hole in the top of the tank.
2. Refer to Fig. 3, slide the rubber gasket up to the bottom of the fuel sender flange.
Next, slide the second flange over fuel sender to bottom of rubber gasket.
Align the pre-threaded holes in mounting flange and rubber gasket with those in fuel sender flange.
Use 25 mm screw to loosely attach mounting flange.
Do not tighten completely.
3. Refer to Fig. 4 and slip the fuel sender assembly into the 59 mm hole turning until it goes into the tank.
4. Tighten all screws until the flange is fully seated on to the gasket.
5. Connect the gauge sensor wire to centre stud terminal.
6. Connect the negative wire to small terminal.

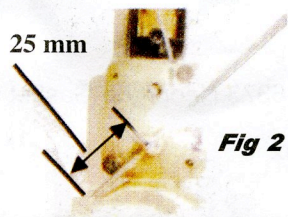
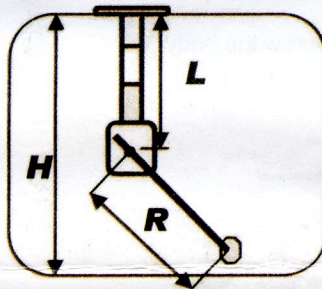
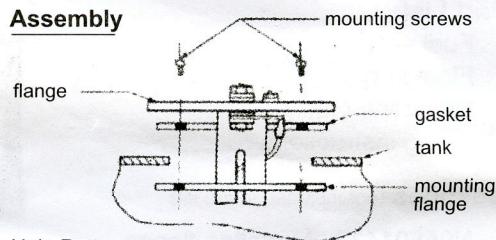

Fig 2



Assembly



Hole Pattern

2.125" (54mm) diameter bolt circle.

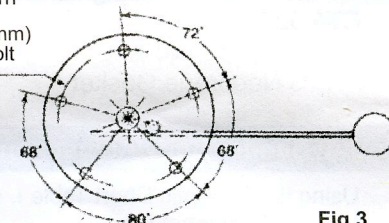

Fig 3

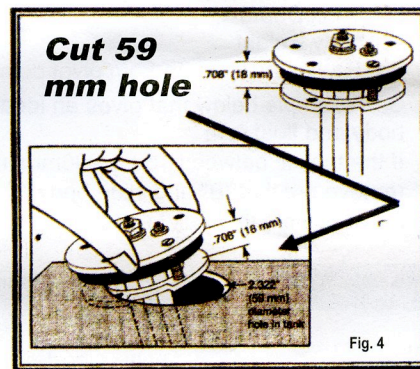

Fig. 4

Table I (Dimensions in mm)

H	L	R
160	80	94
165	82.5	97
170	85	100
175	87.5	103
180	90	106
185	92.5	109
190	95	112
195	97.5	115
200	100	118
205	102.5	121
210	105	124
215	107.5	127
220	110	130
225	112.5	133
230	115	136
235	117.5	139
240	120	142
245	122.5	145
250	125	148
255	127.5	151
260	130	154
265	132.5	157

H	L	R
270	135	160
275	137.5	163
280	140	166
285	142.5	169
290	145	172
295	147.5	175
300	150	178
305	152.5	181
310	155	184
315	157.5	187
320	160	190
325	162.5	193
330	165	196
335	167.5	199
340	170	202
345	172.5	205
350	175	208
355	177.5	211
360	180	214
365	182.5	217
370	185	220
375	187.5	224

H	L	R
380	190	252
385	192.5	256
390	195	260
395	197.5	264
400	200	268
405	202.5	272
410	205	276
415	207.5	280
420	210	284
425	212.5	288
430	215	292
435	217.5	296
440	220	300
445	222.5	304
450	225	308
455	227.5	312
460	230	316
465	232.5	320
470	235	324
475	237.5	328
480	240	332
485	242.5	336

H	L	R
490	245	340
495	247.5	344
500	250	348
505	252.5	352
510	255	356
515	257.5	360
520	260	364
525	262.5	368
530	265	372
535	267.5	376
540	270	380
545	272.5	384
550	275	388
555	277.5	392
560	280	396
565	282.5	400
570	285	404
575	287.5	408
580	290	412
585	292.5	416
590	295	420
595	297.5	424

Add 25 mm to all values of "R" (this is to allow the arm to be extended 25 mm on the other side of the pivot point)